

GAI 型旋转接头

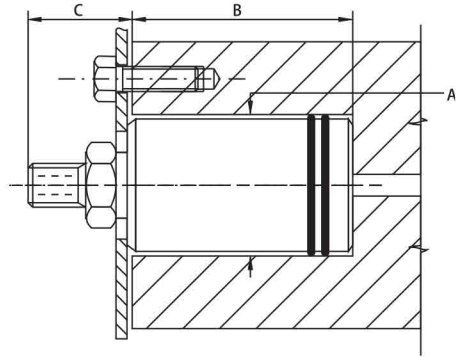

型号	转轴	A*	B	C	重量 (kg)
GAI003002516	M10 X 1 RH	1.22	1.89	0.94	0.15
GAI003002515	G 1/4" (BSP) RH	1.22	1.89	0.94	0.15
GAI006001215	5/8" - 18 UNF RH	1.54	2.13	1.06	0.5
GAI006003601	5/8" - 18 UNF LH	1.54	2.13	1.06	0.5
GAI006002372	G 1/4" (BSP) RH	1.54	2.13	1.06	0.5
GAI006003602	G 1/4" (BSP) LH	1.54	2.13	1.06	0.5
GAI009002780	5/8" - 18 UNF RH	1.73	2.83	1.10	0.5
GAI009003604	5/8" - 18 UNF LH	1.73	2.83	1.10	0.5
GAI009000824	G 3/8" (BSP) RH	1.73	2.83	1.10	0.5
GAI009003603	G 3/8" (BSP) LH	1.73	2.83	1.10	0.5
GAI009001380	M16 X 2 RH	1.73	2.83	1.10	0.5
GAI012000640	3/4" - 16 UNF RH	2.32	3.07	1.46	0.7
GAI012003605	3/4" - 16 UNF LH	2.32	3.07	1.46	0.7
GAI012003477	G 1/2" (BSP) RH	2.32	3.07	1.46	0.7
GAI012003607	G 1/2" (BSP) LH	2.32	3.07	1.46	0.7
GAI012001419	G 3/4" (BSP) RH	2.32	3.07	1.46	0.7
GAI012003606	G 3/4" (BSP) LH	2.32	3.07	1.46	0.7

* 尺寸公差是+0.3/+0.4

介质	压力 (bar)	温度 (°C)	转速 (RPM)
空气	10	121	1,500
冷却液	70	121	3,500
液压油	70	121	3,500

特点和优势

- ▶ 内置式设计，结构紧凑
- ▶ 硬化的不锈钢转轴
- ▶ 优化的平衡式密封，使摩擦力降到最小
- ▶ 运行平稳，无振动
- ▶ 适用于带光刻密封槽的非接触式密封
- ▶ 铝制壳体